

Company

Street, No.

ZIP

City

Contact person

Phone

Mail

Quantity (piece)

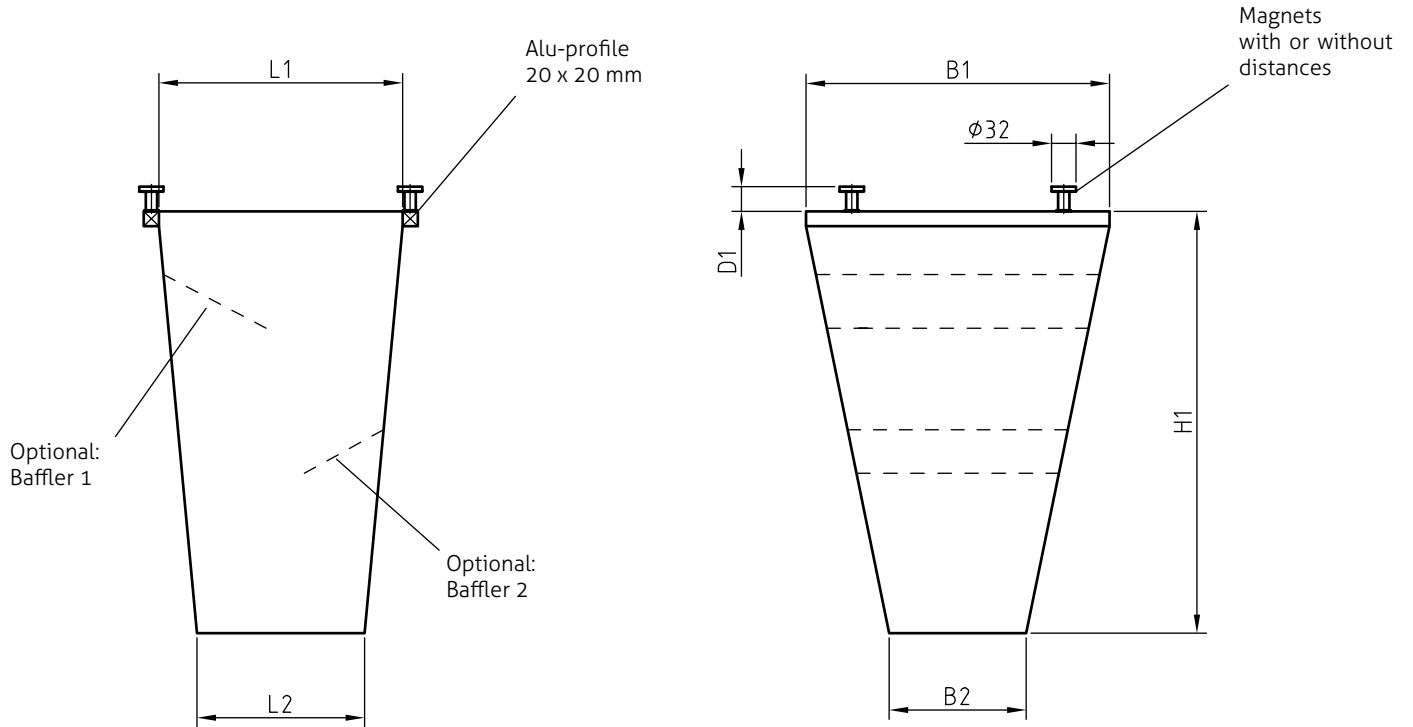

Width

B1= mm

Width of runout

B2= mm

Distance to the tool (min. 8 mm magnetheight)

D1= mm

Height

H1= mm

Length

L1= mm

Length of runout

L2= mm

Options:

Baffle 1 Size of the moulded parts (L x W x H)

Baffle 2 mm

One side cut-out for conveyor (L-side)

One side cut-out for conveyor (B-side)

Material:

FM100.001 (PE, blue)

FM100.003 (PVC, blue)

FM100.005 (PP, white, FDA)

FM100.002 (PVC, silver)

FM100.004 (Kevlar, silver)

FM100.006 (PBT, white)